

BIRD UNLOADER

Model No. ABU-313



The Cantrell Automatic Bird Unloader is USDA approved and operates on any type shackle configuration. Designed for maximum processing line efficiency, the unloader is directly driven from the overhead conveyor. This insures synchronicity with the line providing positive positioning and reduced shackle bending or jamming. The unloader fits easily into any overhead configuration, is simple to install and requires minimal maintenance. As always, Cantrell assures you the ultimate in processing equipment efficiency.

Cantrell Machine Co., Inc.

P O Box 757
1400 S. Bradford Street
Gainesville, Ga. 30503

Phone: 770-536-3611
Fax: 770-531-0832
www.cantrell.com



BIRD UNLOADER

Model No. ABU-313

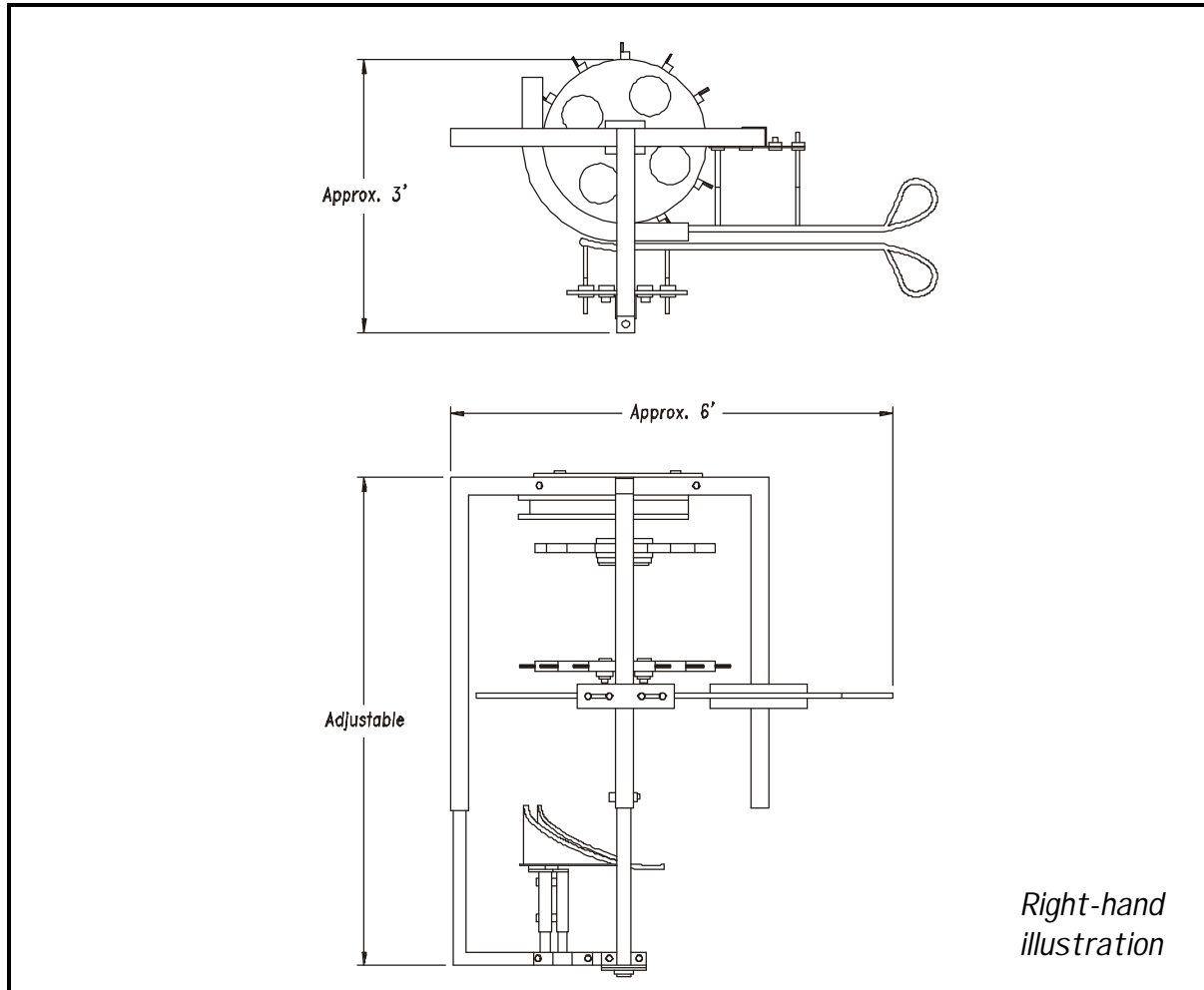

TECHNICAL SPECIFICATIONS

Capacity:	Up to 5,000 BPH
Position In Line:	Before whole bird chiller
Rotation:	Rotation varies (right-hand illustration)
Height:	Determined by setup
Length:	Approximately 6'
Width:	Approximately 3'

The specifications as stated herein are the most current at the time of publication. However, consistent with our standard of continual product improvement, we reserve the right to change the design without notice or obligation to modify any equipment previously sold or delivered.

Cantrell Machine Co., Inc.

P O Box 757 1400 S. Bradford Street

Gainesville, Ga. 30503

770-536-3611

(Fax) 770-531-0832