

CROPPER

Model No. CHC-20

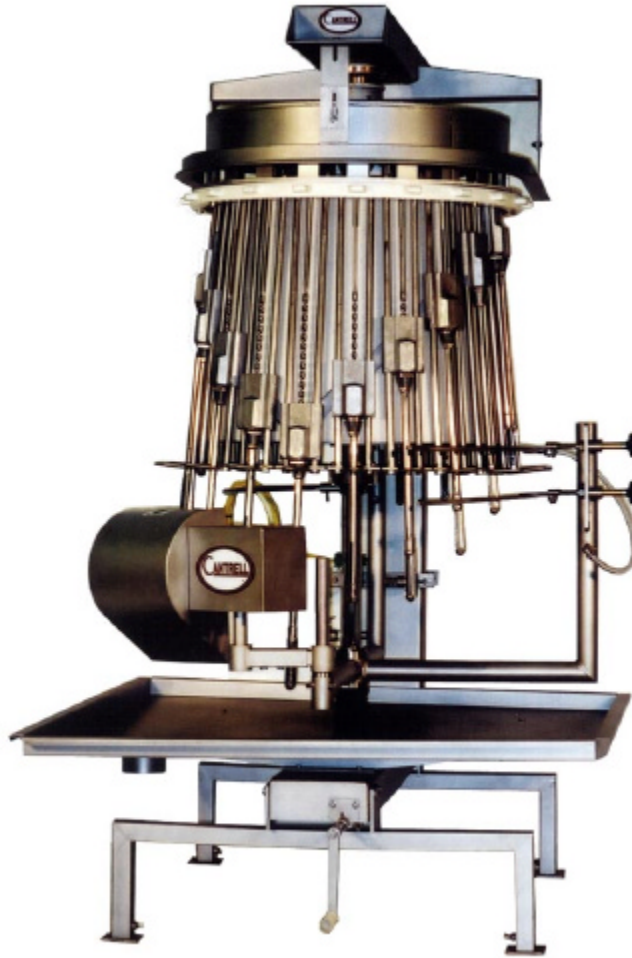

Cantrell's Automatic Cropper is positioned into the eviscerating line after the Gizzard Harvester and before the Neck Breaker. With a capacity of 8,500 birds per hour, this machine is one of the most efficient Croppers available. Its function is to remove any remaining crops and portions of wind pipe that may remain within the bird. The Cropper is not specifically designed to remove all wind pipes, but it does remove a high percentage along with the crops that may remain.

Summary: The probe starts to rotate as it enters the neck cavity from the abdominal cavity and continues its path between the neck and neck skin, exiting at the point where the head has been removed. Now loaded with crop, the probe continues its downward path through a rotating brush where crop and other tissue are unloaded and the probe is cleansed before reversing its course returning to the ready position.

The Cropper is a 20-unit machine that operates in a 180° turn in the eviscerating line and accepts birds shackled on 6" centers.

Cantrell Machine Co., Inc.

P O Box 757
1400 S. Bradford Street
Gainesville, Ga. 30503

Phone: 770-536-3611
Fax: 770-531-0832
www.cantrell.com



CROPPER
Model No. CHC-20

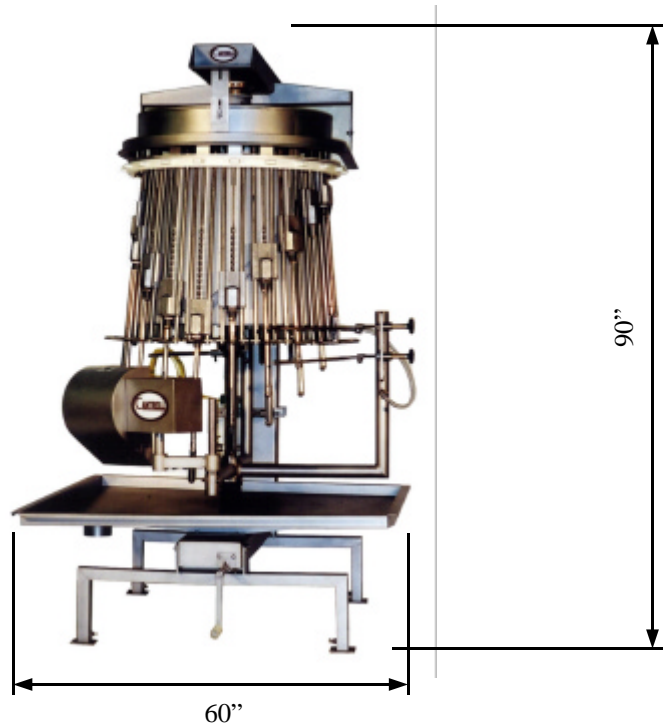

TECHNICAL SPECIFICATIONS

WATER:	3/4" CONNECTION, 4 GPM
ELECTRICITY:	(1) 2 HP MOTOR
CAPACITY:	8,500 BIRDS PER HOUR
POSITION IN LINE:	AFTER THE GIZZARD HARVESTER, BEFORE NECK BREAKER
ROTATION:	DETERMINED FACING BACK OF BIRD
HEIGHT:	90"
WIDTH:	60"
DEPTH:	60"

The specifications as stated herein are the most current at the time of publication. However, consistent with our standard of continual product improvement, we reserve the right to change the design without notice or obligation to modify any equipment previously sold or delivered.