

# AUTOMATIC GIBLET WRAPPER

Model No. CGW-9, CGW-11, CGW-13



The Cantrell Automatic Giblet Wrapper wraps giblets (heart, liver, gizzard and neck) individually at a rate of 100 packages per minute. Located in front of the giblet holding bin, separated giblets are placed in individual trays of the gib-wrap infeed conveyor. The conveyor carries the giblets to the wrapper and unloads onto specially designed paper. The paper is folded, sealed, perforated and cut to standard size packages. From here a small conveyor can carry the packages to a stuffing table where they can be inserted into the bird cavity.

**Cantrell Machine Co., Inc.**

P O Box 757  
1400 S. Bradford Street  
Gainesville, Ga. 30503

Phone: 770-536-3611  
Fax: 770-531-0832  
[www.cantrell.com](http://www.cantrell.com)



# AUTOMATIC GIBLET WRAPPER

Model No. CGW-9, CGW-11, CGW-13



## ADVANTAGES:

- Saves an average of 3-5 people on a typical 6,000 BPH operation
- Compact design requires little space
- All stainless steel construction
- No air or vacuum required
- Removable covers allow for quick clean-up

## VARIATIONS:

The Automatic Giblet Wrapper is available with 3 different infeed conveyor lengths:

- CGW-9 9 ft. infeed
- CGW-11 11 ft. infeed
- CGW-13 13 ft. infeed

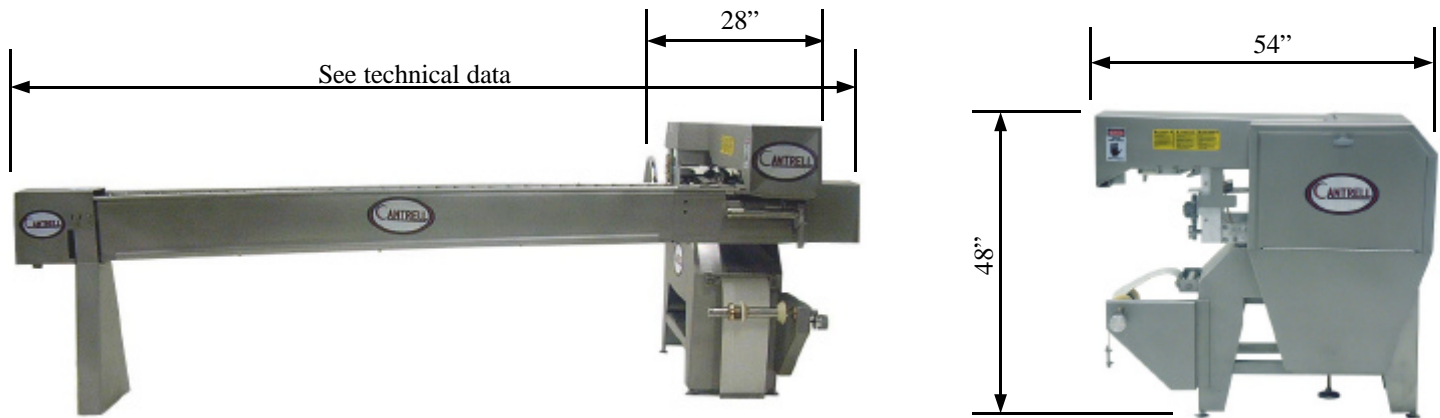

## TECHNICAL SPECIFICATIONS

<b>INFEEED CONVEYOR LENGTH:</b>	CGW-9: 9', CGW-11: 11', CGW-13: 13'
<b>CAPACITY:</b>	100 PACKAGES PER HOUR
<b>TYPE PAPER REQUIRED:</b>	GIBLET WRAP LATEX, 40 LB. WT., 8" WIDE, 5000 LIN. FT./ROLL
<b>INSTALLED POWER:</b>	1 X 1 HP
<b>NET WEIGHT:</b>	700 LBS.
<b>GROSS WEIGHT:</b>	1000 LBS.

The specifications as stated herein are the most current at the time of publication. However, consistent with our standard of continual product improvement, we reserve the right to change the design without notice or obligation to modify any equipment previously sold or delivered.

Cantrell Machine Co., Inc.

P O Box 757 1400 S. Bradford Street Gainesville, Ga. 30503 770-536-3611 770-531-0832