

GIZZARD DEFATTER

Model No. DF-1



The Cantrell Automatic Gizzard Defatter removes excess fat and contamination from gizzards. After proper processing in the gizzard harvester, gizzards enter the defatter and are thoroughly cleaned and polished by the gentle rotating fingers and high pressure washing action. The stainless steel construction assures easy clean-up and the elimination of rust problems. Also available in a model for turkeys.

Cantrell Machine Co., Inc.

P O Box 757
1400 S. Bradford Street
Gainesville, Ga. 30503

Phone: 770-536-3611
Fax: 770-531-0832
www.cantrell.com



GIZZARD DEFATTER

Model No. DF-1

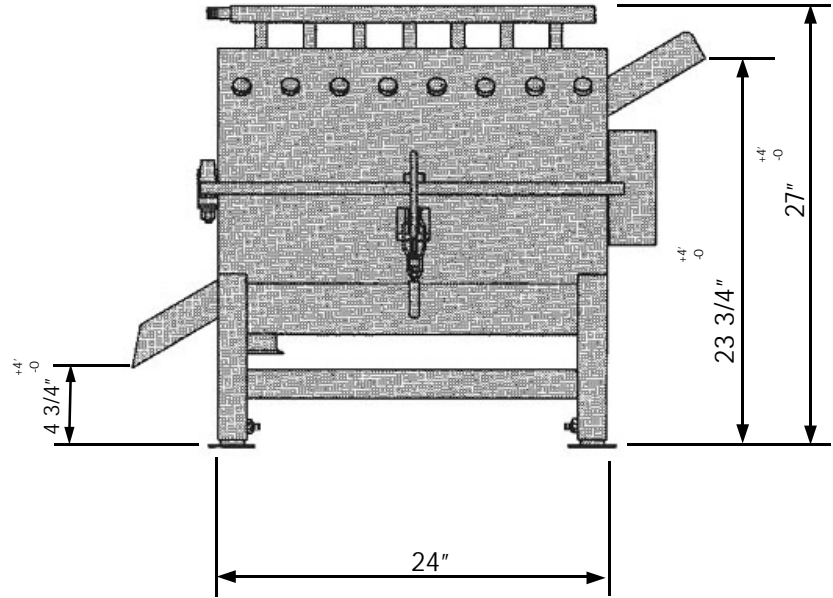
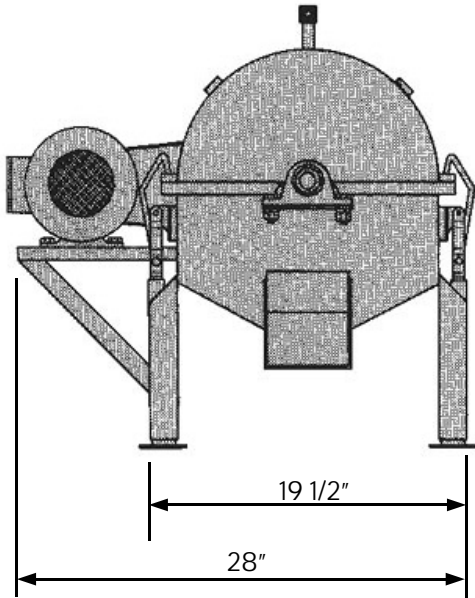

Also available in a larger model for Turkey

TECHNICAL SPECIFICATIONS

Position In Line:	After Automatic Gizzard Harvester
Capacity:	6000 gizzards per hour
Installed Power:	1 X 1 HP
Water Connection:	3/4" water
Height:	27"
Length:	24"
Width:	28"

The specifications as stated herein are the most current at the time of publication. However, consistent with our standard of continual product improvement, we reserve the right to change the design without notice or obligation to modify any equipment previously sold or delivered.

Cantrell Machine Co., Inc.

P O Box 757 1400 S. Bradford Street Gainesville, Ga. 30503 770-536-3611 770-531-0832