

# GIZZARD HARVESTER

Model No. CGH-2000



The new CGH-2000 was designed with proficiency and ease in mind. This harvester provides superior performance harvesting 182 gizzards per minute with a guaranteed recovery rate of 90% and a ready-to-cook rate equal to or better than the current market machine. This exceptional output is followed by a reduced water usage rate of 20-25 gallons. Safety features include electronic and mechanical shear pins which protect the harvester from damage should any foreign matter enter the machine. Furthermore, the new see-through design provides complete access to the interior allowing easy cleaning and maintenance. Proven behind Nutech and Meyn Maestro Systems, the CGH-2000 is a must for any quality processor.

#### Highlights

- **Guaranteed 90% recovery**
- **Reduced Water Usage Rate 20-25 gallons**
- **Easy Access Design**

**Cantrell Machine Co., Inc.**

P O Box 757  
1400 S. Bradford Street  
Gainesville, Ga. 30503

Phone: 770-536-3611  
Fax: 770-531-0832  
[www.cantrell.com](http://www.cantrell.com)



# GIZZARD HARVESTER

Model No. CGH-2000

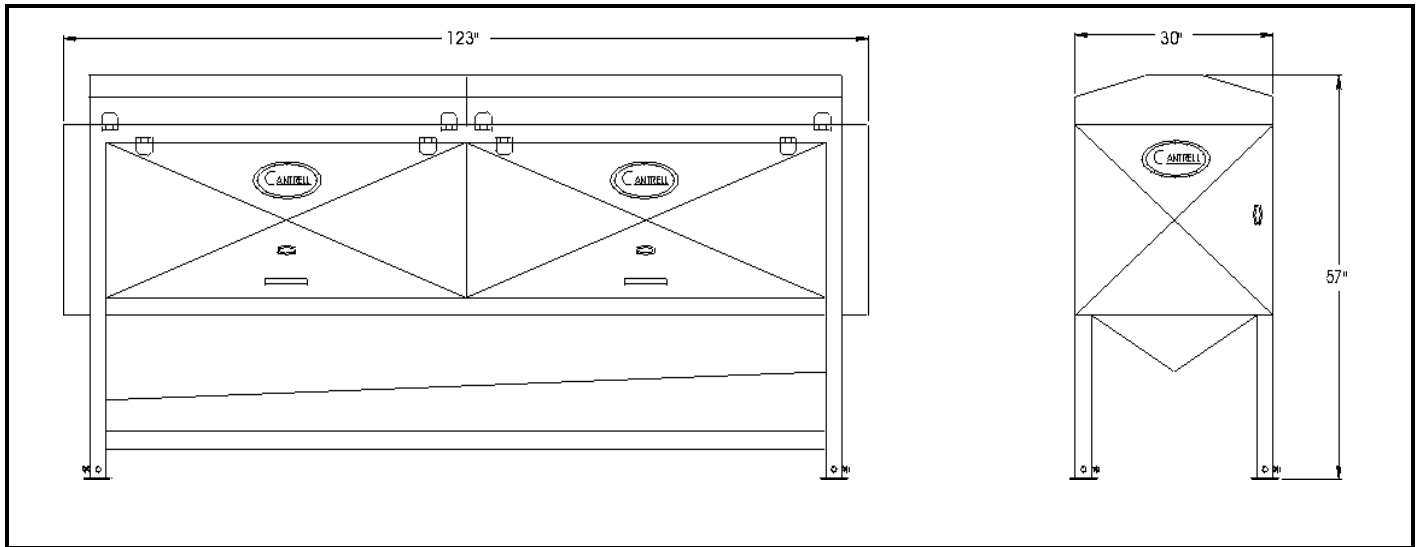

## TECHNICAL SPECIFICATIONS

<b>Position In Line:</b>	After Heart & Liver Harvester
<b>Construction:</b>	Stainless Steel
<b>Net Weight:</b>	900 lbs.
<b>Gross Weight:</b>	1250 lbs.
<b>Width:</b>	30"
<b>Length:</b>	123"
<b>Height:</b>	57"

The specifications as stated herein are the most current at the time of publication. However, consistent with our standard of continual product improvement, we reserve the right to change the design without notice or obligation to modify any equipment previously sold or delivered.

Cantrell Machine Co., Inc.

P O Box 757 1400 S. Bradford Street Gainesville, Ga. 30503 770-536-3611 (Fax) 770-531-0832