

# GIZZARD HARVESTER

Model No. CGH-8000

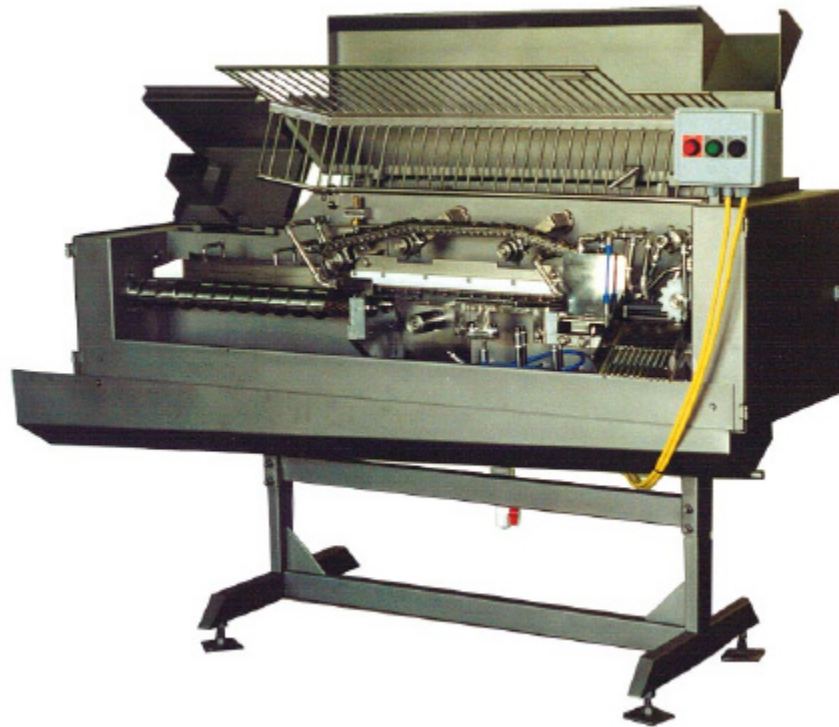

The Cantrell Gizzard Harvester is designed to harvest 100 gizzards a minute with recovery rates in the high 90's and ready-to-cook in the 80's. Besides high recovery rates and great performance, the CGH-8000 has many built in safety features including a large number of shear pins which protect the harvester if foreign matter enters the machine. High speed, exemplary performance and safety features ensure a quality gizzard harvesting system for your processing plant.

**Cantrell Machine Co., Inc.**

P O Box 757  
1400 S. Bradford Street  
Gainesville, Ga. 30503

Phone: 770-536-3611  
Fax: 770-531-0832  
[www.cantrell.com](http://www.cantrell.com)



# GIZZARD HARVESTER

Model No. CGH-8000

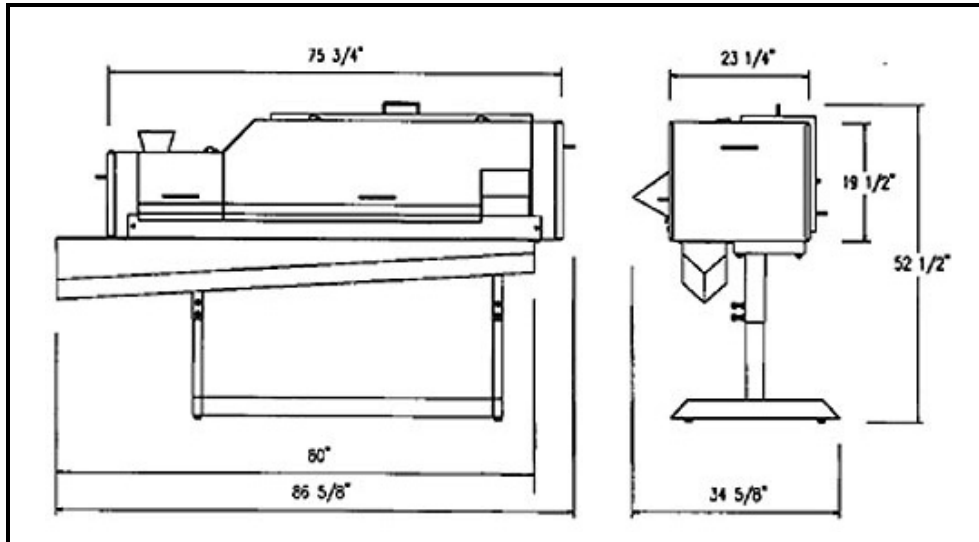

## TECHNICAL SPECIFICATIONS

<b>Position In Line:</b>	After Heart & Liver Harvester
<b>Construction:</b>	Stainless Steel
<b>Net Weight:</b>	900 lbs.
<b>Gross Weight:</b>	1250 lbs.
<b>Width:</b>	34 5/8"
<b>Length:</b>	86 5/8"
<b>Height:</b>	52 1/2"

The specifications as stated herein are the most current at the time of publication. However, consistent with our standard of continual product improvement, we reserve the right to change the design without notice or obligation to modify any equipment previously sold or delivered.

Cantrell Machine Co., Inc.

P O Box 757 1400 S. Bradford Street

Gainesville, Ga. 30503

770-536-3611

770-531-0832