

▶ Gizzard Inspection Stations Model No. CGI-100, CGI-200, CGI-300



3-station model



2-station model

▶ Cantrell Gizzard Inspection Stations are some of the finest in the industry, capable of handling 140-182 gizzards per minute. Each roller group is operated by a designated panel box which controls the start, stop and manual reverse of the rollers. The rear set of automatic rollers receives the gizzards from the harvesting and defatting line and removes any remaining peel. Gizzards are then pulled forward for inspection and any gizzard requiring further cleaning is then guided over the manual rollers. The smooth, flush surface allows gizzards to be moved and inspected easily. Inspection stations are available in 1, 2 or 3-station models and require water and electricity for operation. Each is constructed of quality stainless steel assuring easy clean-up and minimal maintenance.

➤ Gizzard Inspection Stations Model No. CGI-100, CGI-200, CGI-300

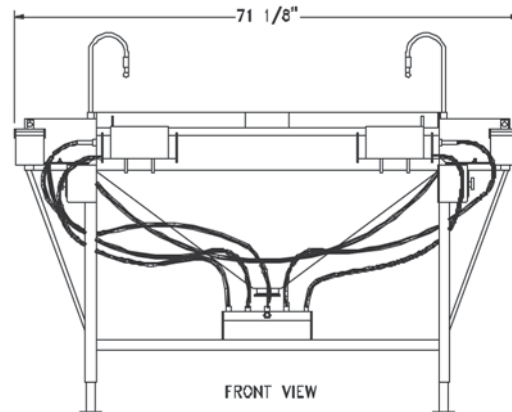
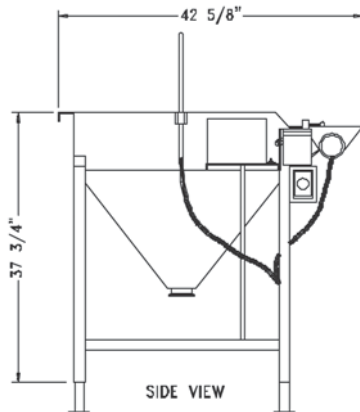
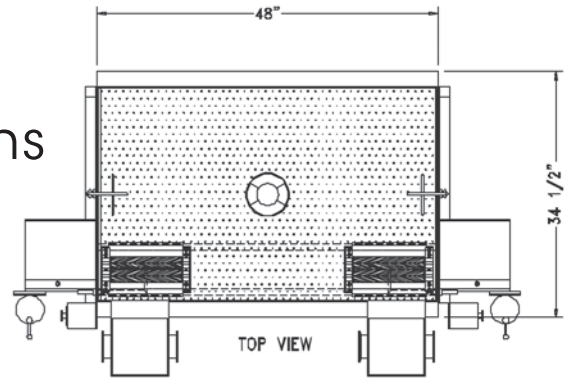

TECHNICAL SPECIFICATIONS

| | |
|-------------------|--------------------------------------|
| Position In Line: | After Gizzard Harvester and Defatter |
| Capacity: | 140-182 Gizzards Per Minute |
| Power: | 1 HP / .75 kw Per Roller Set |
| Water: | 3/8 in. connection |
| Width: | 28 in. to 48 in. / 711 mm to 1219 mm |
| Length: | 30 in. to 71 in. / 762 mm to 1803 mm |
| Height: | 38 in. to 54 in. / 965 mm to 1372 mm |

The specifications as stated herein are the most current at the time of publication. However, consistent with our standard of continual product improvement, we reserve the right to change the design without notice or obligation to modify any equipment previously sold or delivered.