

▶ Hock Cutter Model No.PHC-4



▶ The Cantrell Automatic Hock Cutter Model PHC-4 is a field proven technique of cutting hocks on broilers as well as hens.

Due to the simple design of few moving parts, you can expect the Cantrell Hock Cutter to give you continuous day-in, day-out precision cutting performance. By use of a specially designed chain, the hock cutter automatically positions and severs the hock joint by nicking, disjuncting and cutting the joint completely off or to the last tendon for auto rehousing.

➤ Hock Cutter Model No.PHC-4

Features

- Available with an electric or hydraulic motor.
- Plenty of adjustments for variance in different sizes of birds.
- Available in all stainless or all aluminum frame.

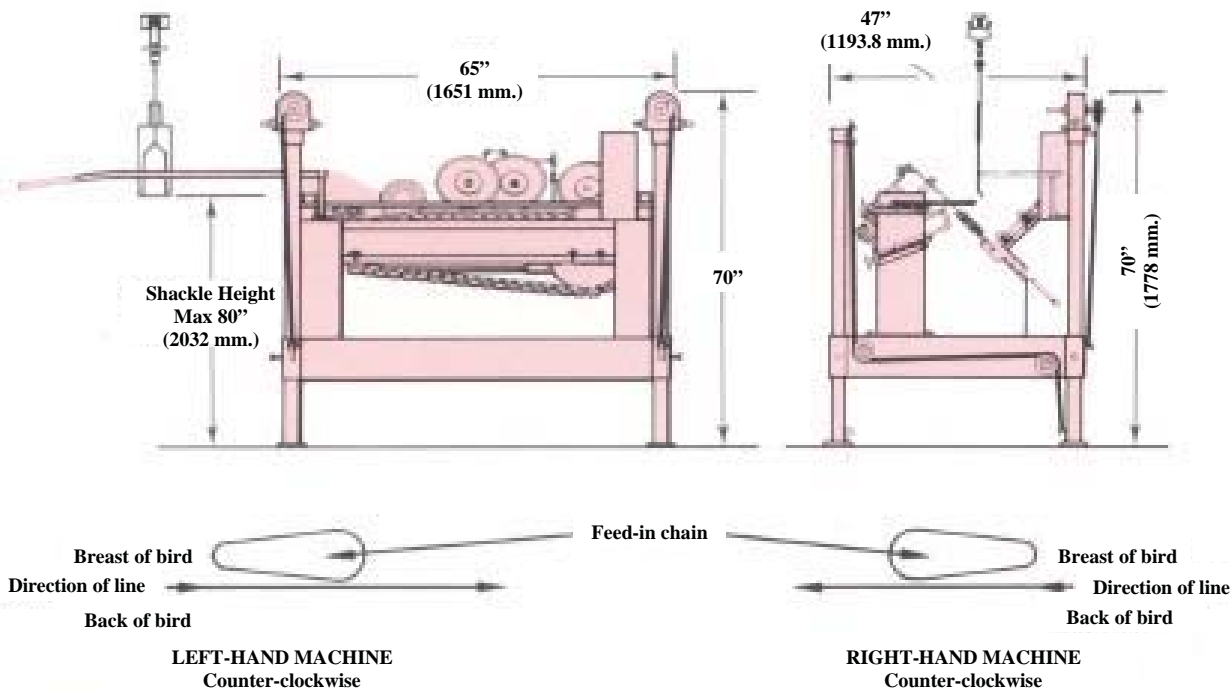

TECHNICAL SPECIFICATIONS

Capacity:	7200 BPH
Installed Power:	(3X) 2HP / 1.48 kw
Plumbing:	2 x 3/8 in. / 54 mm water connection
Net Weight:	900 lbs. / 408 kg
Gross Weight:	1300 lbs. / 590 kg
Crated Volume:	144 ft. ³ / 4.41 m ³

The specifications as stated herein are the most current at the time of publication. However, consistent with our standard of continual product improvement, we reserve the right to change the design without notice or obligation to modify any equipment previously sold or delivered.