

HELICAL LINE DIVIDER

Model No. GLD 300-B

The Helical Line Divider offers the optimum in design efficiency to provide the processing plant a line divider that is virtually maintenance free.

The Helical Line Divider will operate on a two piece or rigid shackle and eliminates hang-ups. It provides a rigid work area on the line for the operator or inspector, as the divider keeps the shackle firm on the divider bar for proper positioning for working bird and inspection.

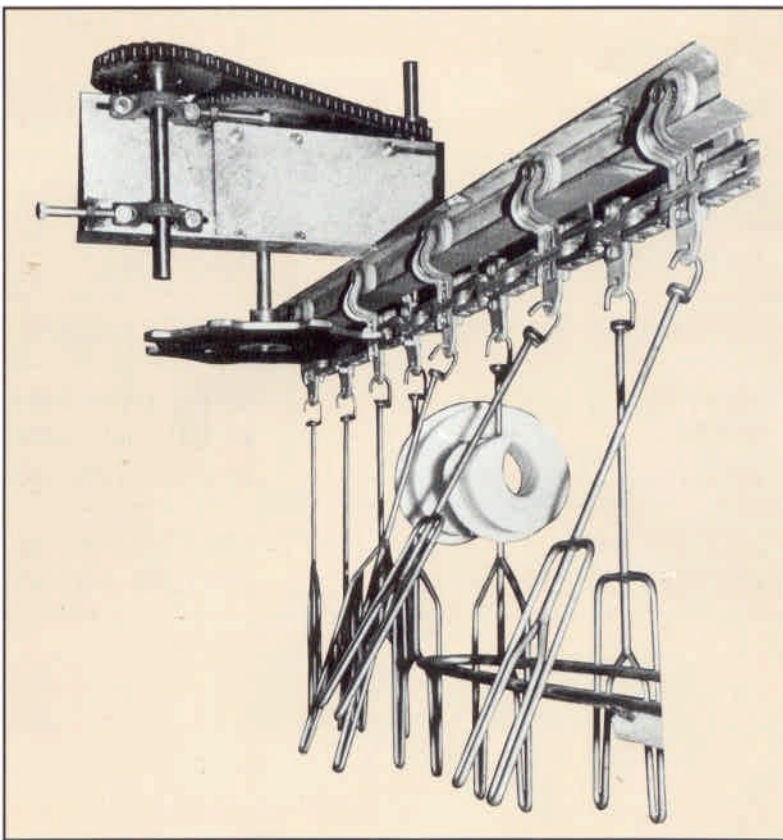
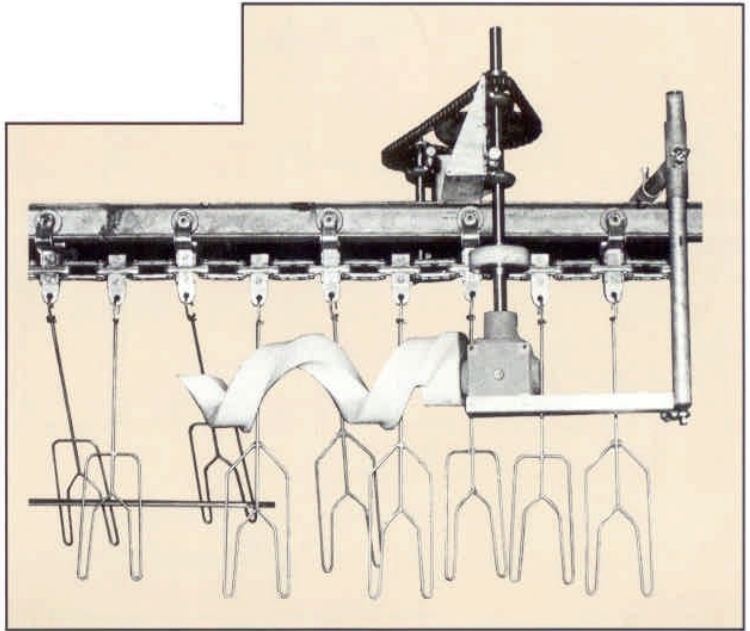

The Helical Line Divider is exclusive in the industry, reduces spare shackle inventory, allows for only one type shackle to be used in plant; and the versatility of the Line Divider makes it applicable for other bird presentation to other personnel on eviscerating line.

Cantrell Machine Co., Inc.

P O Box 757
1400 S. Bradford Street
Gainesville, Ga. 30503

Phone: 770-536-3611
Fax: 770-531-0832
www.cantrell.com

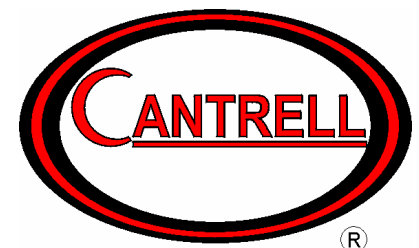

HELICAL LINE DIVIDER

Model No. GLD 300-B

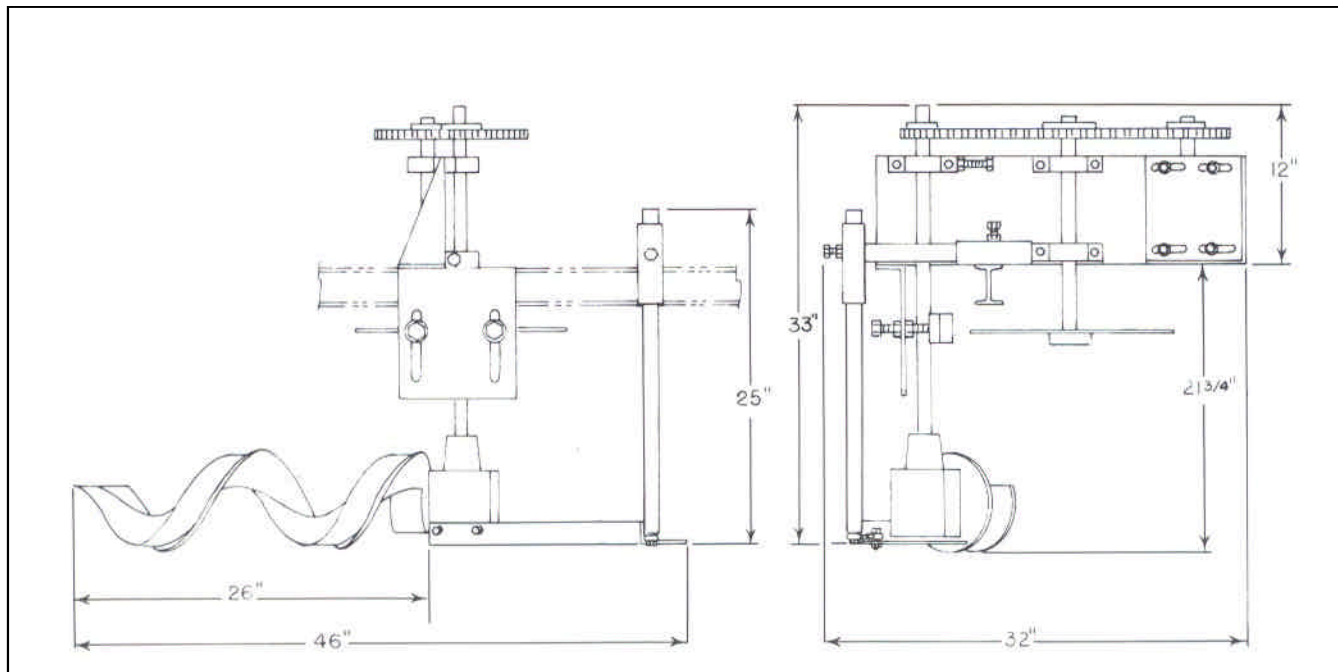

Power:	Driven by overhead
Capacity:	6,000 BPH
Position in Line:	After Automatic Eviscerators
Net Weight:	135 LBS. / 61 KG
Gross Weight:	215 LBS. / 97 KG
Height:	25 IN. / 635 MM
Length:	46 IN. / 1168 MM
Width:	32 IN. / 812 MM

The specifications as stated herein are the most current at the time of publication. However, consistent with our standard of continual product improvement, we reserve the right to change the design without notice or obligation to modify any equipment previously sold or delivered.

Cantrell Machine Co., Inc.

P O Box 757 · 1400 S. Bradford Street · Gainesville, Ga. 30503 · 770-536-3611 · (Fax) 770-531-0832