

NECK SKIN CUTTER

Model No. MS-1

The Cantrell Automatic Neck Skin Cutter provides a consistently accurate cut by means of a circular stainless steel blade.

The MS-1 is mounted above the overhead conveyor and is driven by a 1 HP motor. Usually located at the end of the eviscerating line, the MS-1 can also be installed over giblet chillers, allowing necks to be dropped directly below.

Its compact design requires little space and minimal moving parts mean easy maintenance and clean-up. Necessary service is limited to circular blade sharpening and bearing lubrication.

Constructed of high grade stainless steel.

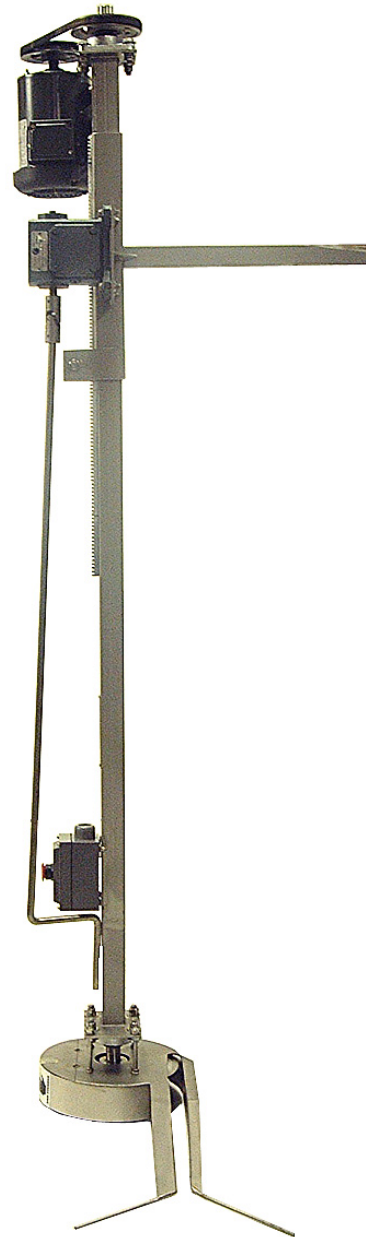

Cantrell Machine Co., Inc.

P O Box 757
1400 S. Bradford Street
Gainesville, Ga. 30503

Phone: 770-536-3611
Fax: 770-531-0832
www.cantrell.com



NECK SKIN CUTTER

Model No. MS-1

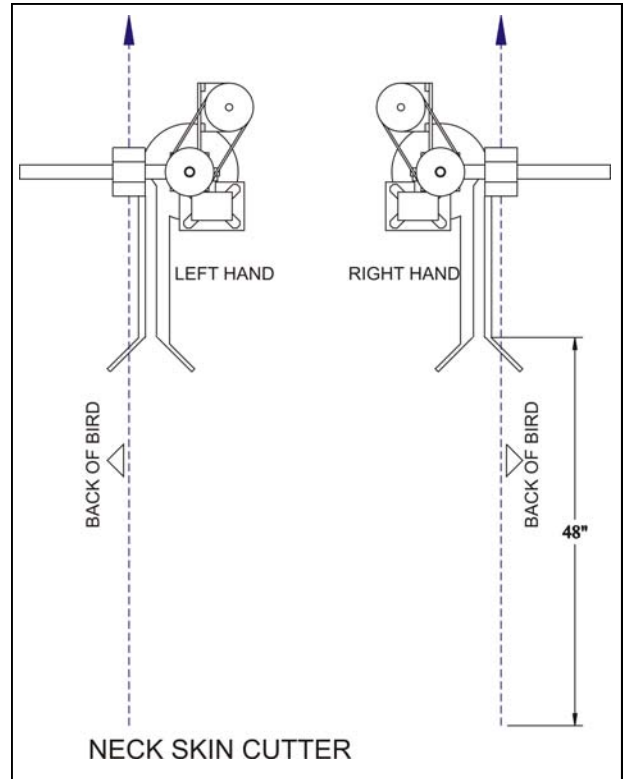
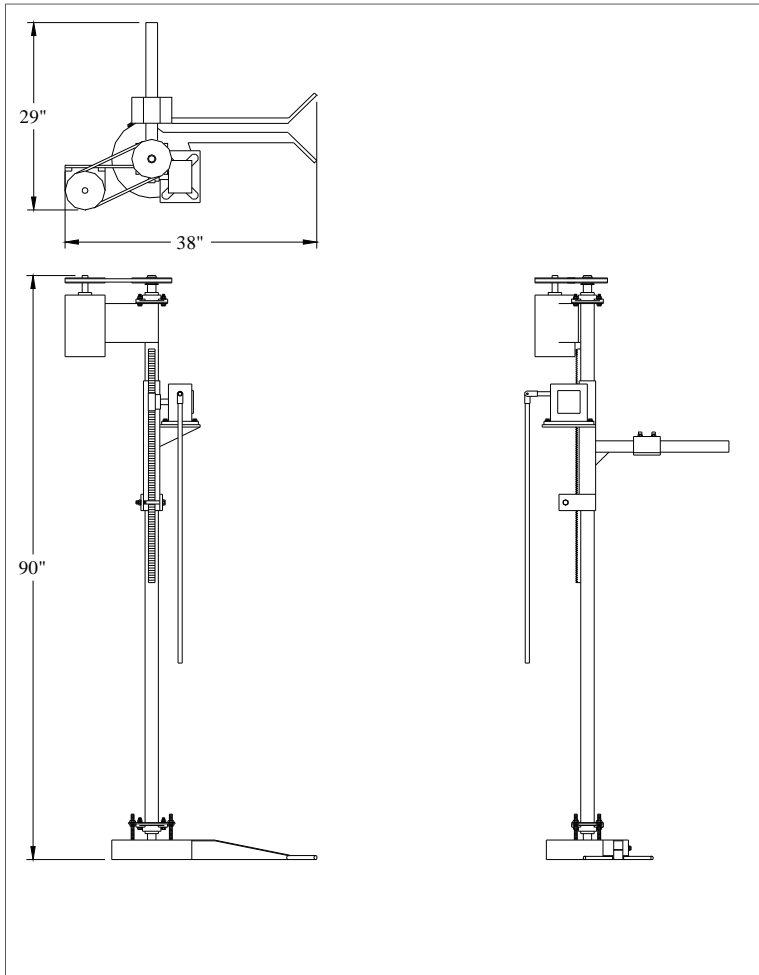

TECHNICAL SPECIFICATIONS

Position In Line:	After eviscerating and before whole bird chilling
Capacity:	6000 Birds per hour
Installed Power:	1 H.P. motor
Net Weight:	130 lbs.
Gross Weight:	272 lbs.
Width:	29"
Height:	90"

The specifications as stated herein are the most current at the time of publication. However, consistent with our standard of continual product improvement, we reserve the right to change the design without notice or obligation to modify any equipment previously sold or delivered.

Cantrell Machine Co., Inc.

P O Box 757 · 1400 S. Bradford Street · Gainesville, Ga. 30503 · 770-536-3611 · (Fax) 770-531-0832