

▶ Automatic Picker Model No. CP-80



▶ The Cantrell Automatic Disc Picker is suitable for various breeds and sizes of poultry. The Picker is designed to gently remove those hard-to-get feathers with the use of a specially-designed disc and picking fingers. The frame allows for easy adjustment of picking banks when varying bird sizes are frequent. Adjustments can be made from all four corners to provide perfect positioning of the



picking discs on the bird regardless of size. The discs are driven in opposing directions by motors and belts. A continuous flow of water ensures the picking fingers are kept wet, preventing dry out and ensuring feathers are released into the drain. Constructed of stainless steel, the Automatic Disc Picker is also available in a 40 disc model.

➤ Automatic Picker Model No. CP-80

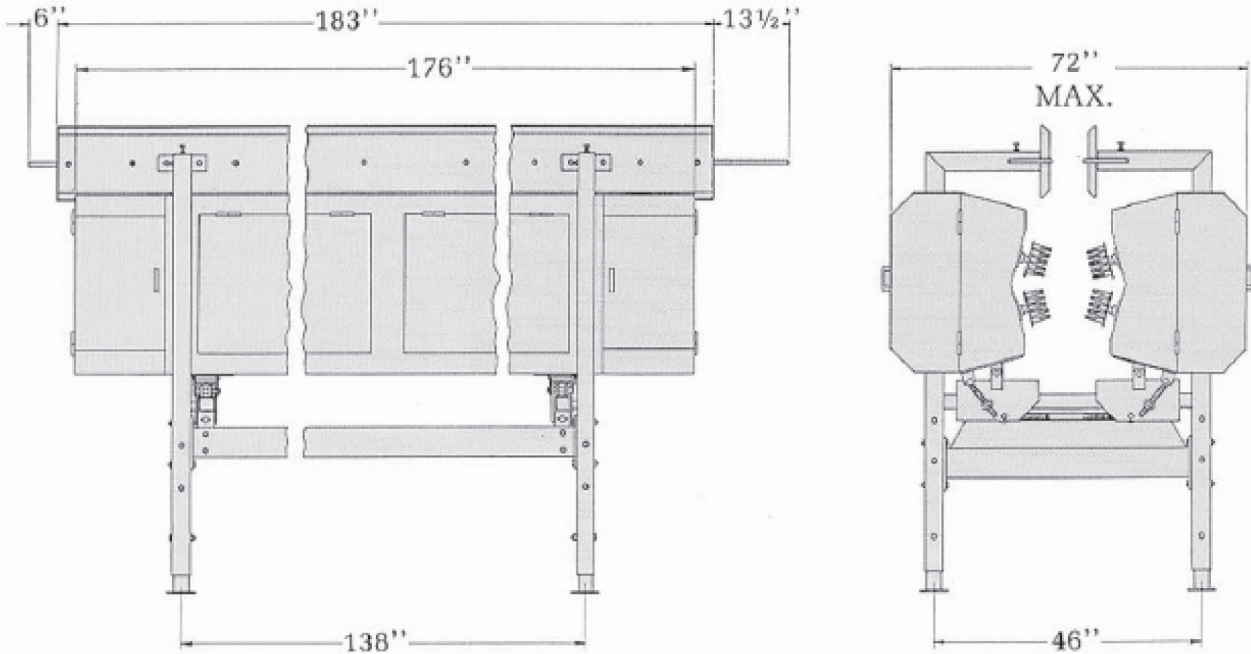

TECHNICAL SPECIFICATIONS

Drive:	(8) 3 HP / (8) 2.2 kw or 5 HP / 3.7 kw
Water Connection:	3/4 in. Dia.
No. of Finger Discs:	80
No. of Fingers per Discs:	(optional) 10, 12 or 15
Water Usage:	12 GPM

The specifications as stated herein are the most current at the time of publication. However, consistent with our standard of continual product improvement, we reserve the right to change the design without notice or obligation to modify any equipment previously sold or delivered.