

▶ Rotary Separator (Offal) Model No. Offal-OS-1

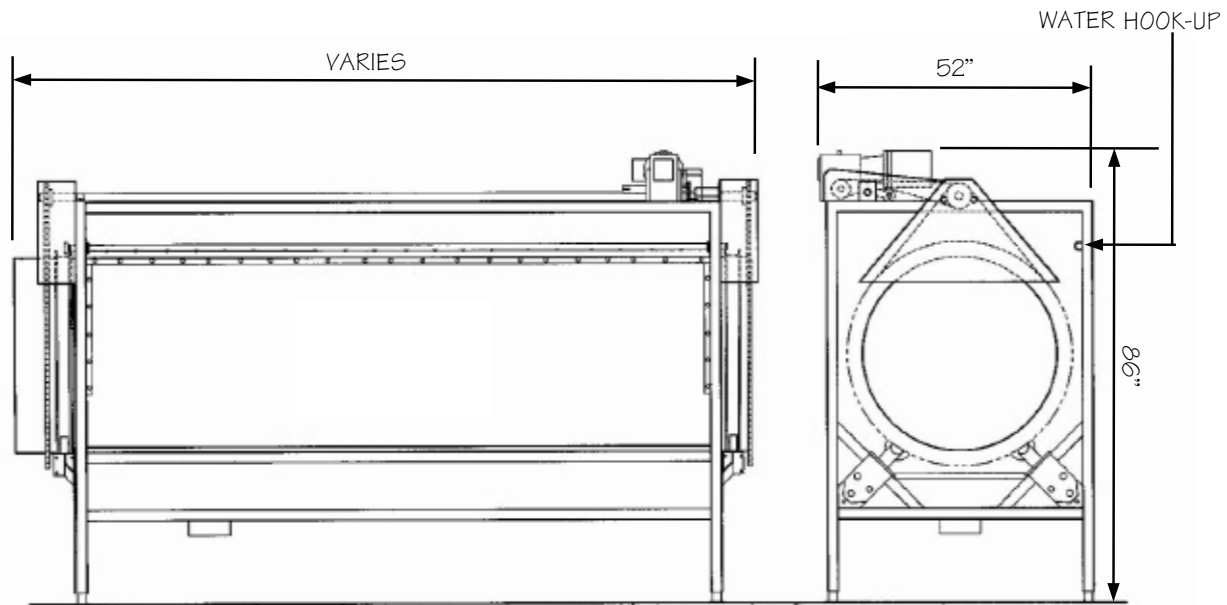

▶ The Cantrell Rotary Separator for offal separates water from the refuse. The perforated stainless steel drum can be supplied either belt or chain driven. This unit is manufactured with stainless steel auger flights inside the drum to ensure the offal is moved through the separator quickly. Standard diameter is 38" although other diameters are available. The offal separator is constructed of heavy duty stainless steel.

➤ Rotary Separator (Offal) Model No. Offal-OS-1



TECHNICAL SPECIFICATIONS

Position in Line:	Offal room
Connection:	1 in. water hook up
Power:	(1) 1 1/2 HP / 1.1 kw
Capacity:	According to customer specification
Width:	52 in. / 1321 mm (overall)
Length:	8 ft. / 2438 mm, 10 ft. / 3048 mm, 12 ft. / 3658 mm, 14 ft. / 4267 mm (standard)
Height:	Max 86 in. / 2184 mm

The specifications as stated herein are the most current at the time of publication. However, consistent with our standard of continual product improvement, we reserve the right to change the design without notice or obligation to modify any equipment previously sold or delivered.