

## ▶ Rotary Separator (Feather) Model No. Feather-FS-1

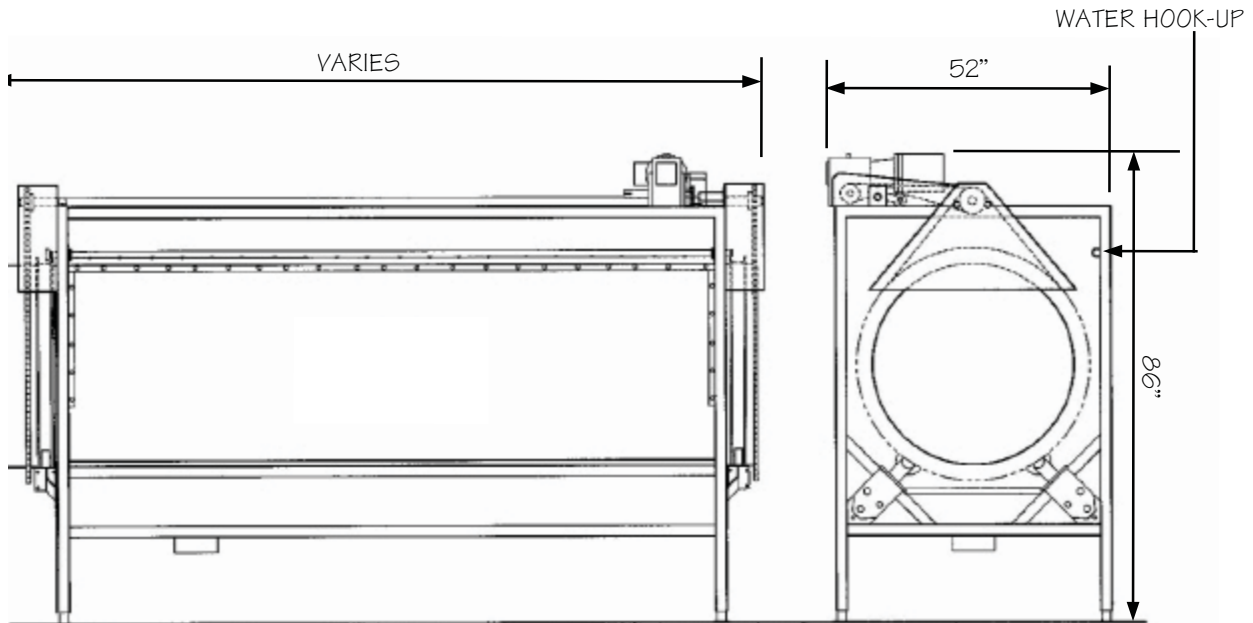

▶ The Cantrell Rotary Separator for feathers separates water from the feathers. The perforated stainless steel drum can be supplied either belt or chain driven. Standard diameter is 38" although other diameters are available. The feather separator is constructed of heavy duty stainless steel.

## ➤ Rotary Separator (Feather) Model No. Feather-FS-1



### TECHNICAL SPECIFICATIONS

|                   |  |
|-------------------|--|
| Position in Line: | Offal room   |
| Connection:       | 1 in. water hook up  |
| Power:            | (1) 1 1/2 HP / 1.1 kw  |
| Capacity:         | According to customer specification  |
| Width:            | 52 in. / 1321 mm (overall)   |
| Length:           | 8 ft. / 2438 mm, 10 ft. / 3048 mm, 12 ft. / 3658 mm, 14 ft. / 4267 mm (standard) |
| Height:           | Max 86 in. / 2184 mm   |

The specifications as stated herein are the most current at the time of publication. However, consistent with our standard of continual product improvement, we reserve the right to change the design without notice or obligation to modify any equipment previously sold or delivered.