

▶ Counterflow Air Agitated Scalding Model No. SS-300CF

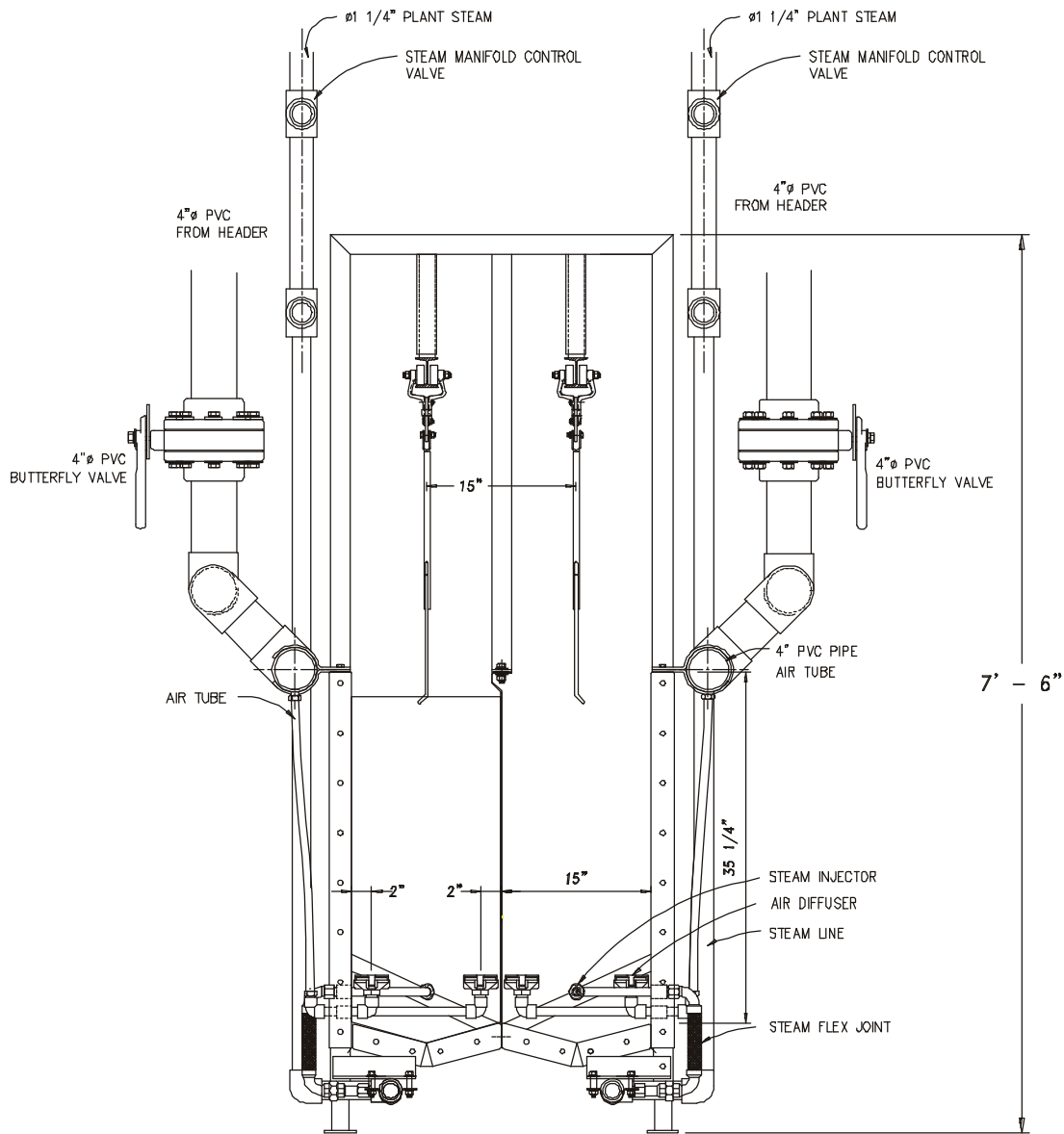

▶ The Cantrell Counterflow Air Agitated Scalding maintains cleaner water and greatly reduces the amount of bacteria coming in contact with the birds. Upon entering the scalding, birds are met by water flowing in a counterflow direction. All scalding lanes are completely divided to ensure the counterflow effect. Birds are submerged in clean water by the time they reach the exit. The modular design allows for easy installation into many settings and configurations. Cantrell understands space is not always plentiful. Regardless of the configuration, all lanes have a v-shaped bottom which simplifies the clean-up process. USDA approved construction.

Counterflow Air Agitated Scalders Model No. SS-300CF



The specifications as stated herein are the most current at the time of publication. However, consistent with our standard of continual product improvement, we reserve the right to change the design without notice or obligation to modify any equipment previously sold or delivered.