

THIGH DEBONING CONVEYOR

Model No. HCP-110-P



The Cantrell Thigh Deboning Conveyor is designed to provide optimum yield and is easily incorporated into any size production requirement. Each specially designed mandrel holds two thighs each. Thighs are affixed to the mandrel by personnel and then precisely cut by alternate operators until the complete yield of meat is attained. The mandrel's are uniformly timed and spaced to each operator allowing one person to become proficient at one motion and insuring a consistent production volume and higher yield of premium meat. The conveyor is suitable for broiler, roaster and turkey thighs.

The Thigh Deboning Conveyor is constructed of stainless steel and UHMW Polymer. The system is practically maintenance free and easy to clean due to the simple design, removable covers and smooth quality construction.

The conveyor capacity can be easily increased at any time by adding additional sections. Each conveyor can be custom fit to your operation and supplied with other product conveyors to make-up a complete system.

Cantrell Machine Co., Inc.

P O Box 757
1400 S. Bradford Street
Gainesville, Ga. 30503

Phone: 770-536-3611
Fax: 770-531-0832
www.cantrell.com

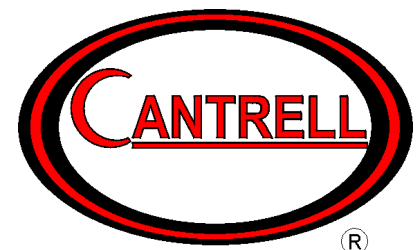

THIGH DEBONING CONVEYOR

Model No. HCP-110-P

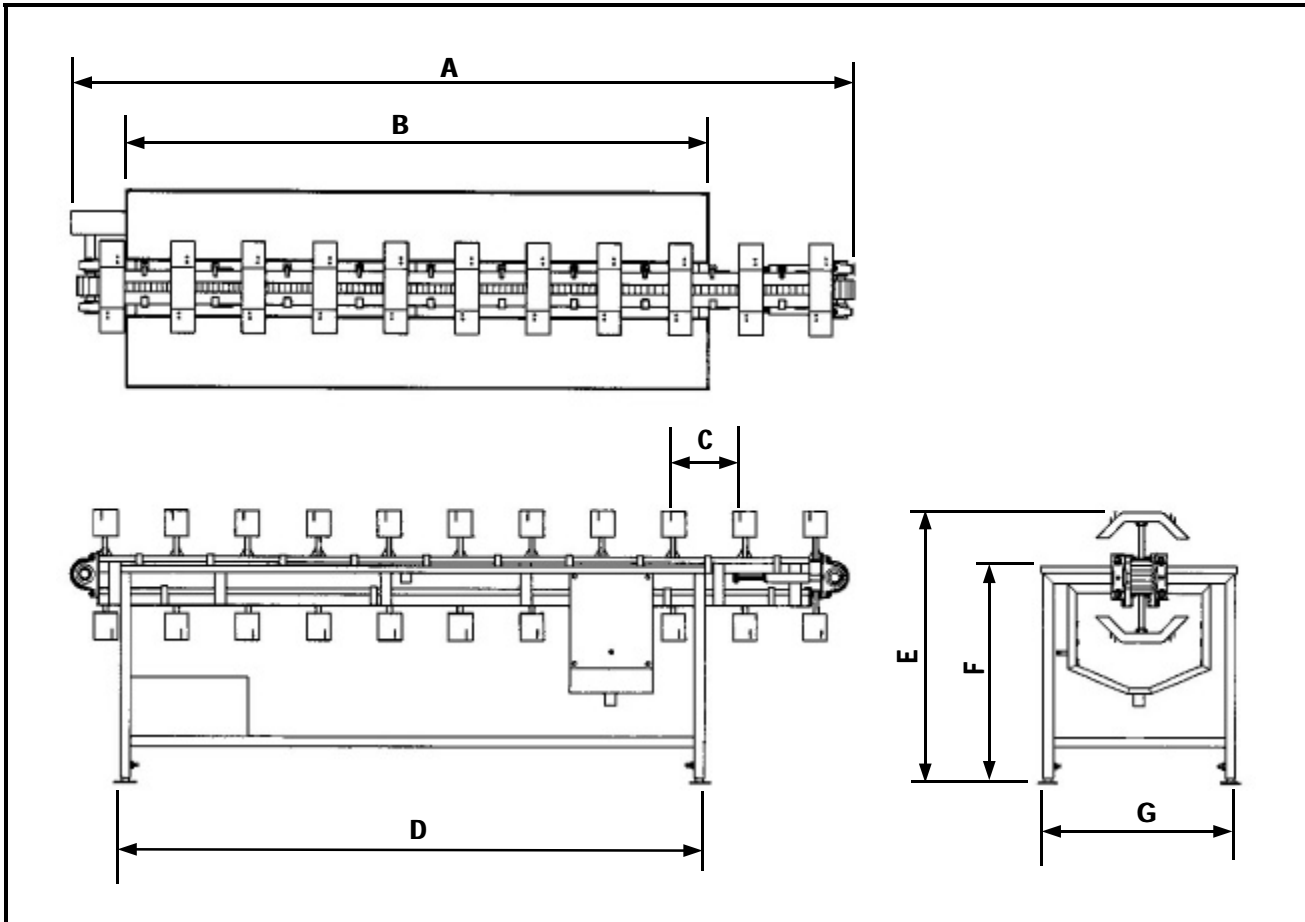

TECHNICAL SPECIFICATIONS

CAPACITY:	60 TO 72 THIGHS PER MINUTE
WATER CONNECTION:	1/4"
INSTALLED POWER:	2 H.P.
"A" LENGTH (CONVEYOR):	(VARIES) PER CUSTOMER SPECS.
"B" LENGTH (TRIM SHELVES):	(VARIES) PER CUSTOMER SPECS.
"C" MANDREL CENTERS:	9", 12", 18" STANDARD (OTHER VARIATIONS AVAILABLE)
"D" LEG CENTERS:	(VARIES) PER CUSTOMER SPECS.
"E" HEIGHT:	(VARIES) PER CUSTOMER SPECS.
"F" TRIM SHELF HEIGHT:	37" STANDARD
"G" WIDTH:	32" STANDARD

The specifications as stated herein are the most current at the time of publication. However, consistent with our standard of continual product improvement, we reserve the right to change the design without notice or obligation to modify any equipment previously sold or delivered.

Cantrell Machine Co., Inc.

P O Box 757 1400 S. Bradford Street Gainesville, Ga. 30503 770-536-3611 770-531-0832