

VACUUM TRANSPORT SYSTEM

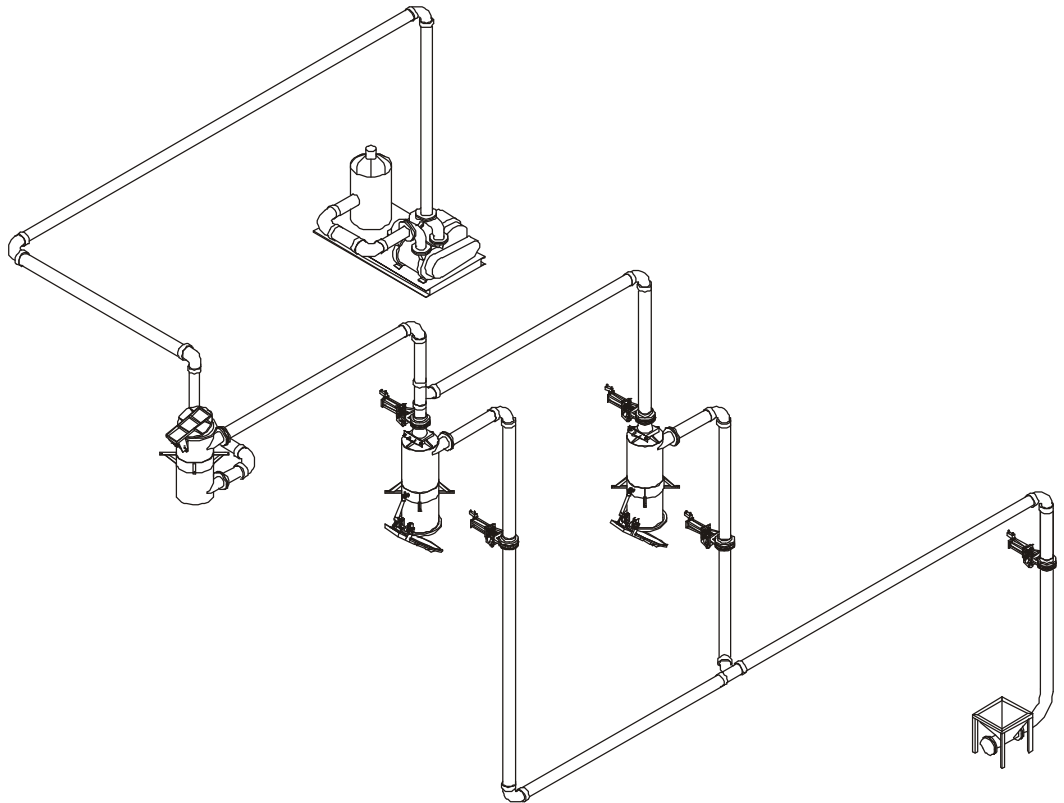

Vacuum Transport Systems help clean your plant while reducing labor and water usage. Cantrell Machine has spent many years developing and perfecting Vacuum Transport Systems that meet the individual needs of our customers. Our PC-based and Touch Screen systems are paramount in the industry. Whether you are moving edible or inedible product, we have a system that can start saving you money right now. Our filter tanks reduce maintenance with easily accessible filters which eliminate the need for additional overflow cyclones. We also have continuous systems for collecting edible products that are self-cleaning. Add weighing hoppers over collection points and you have everything you need to stop pushing barrels and start reducing labor and maintenance, improving sanitation and minimizing the use of costly, hazardous auger systems.

Cantrell Machine Company's Vacuum Transport Systems are the finest in the industry. Our extensive experience in transporting product coupled with our commitment to quality, service and reliability makes our Vacuum Transport System the only choice for quality processors.

Cantrell Machine Co., Inc.

P O Box 757
1400 S. Bradford Street
Gainesville, Ga. 30503

Phone: 770-536-3611
Fax: 770-531-0832
www.cantrell.com

