

COBRA Viscera Harvester

Model No. CVH-14C



The new COBRA Viscera Harvester insures package removal at a better percentage rate than any other machine on the market. Packages are removed in a clean strike without rib or backbone damage.

This forth generation Viscera Harvester offers a completely new spring loaded unit. This unit design provides clean package removal regardless of package position on back of the bird at entry. The overhead drive eliminates the need for air and electricity, therefore reducing maintenance and wear on parts.

The COBRA is available in both 14 and 20 unit models to handle high speed lines with ease. Stainless steel construction and minimal moving parts insure easy clean-up and minimal maintenance. Moreover, your current CVH-14 can be upgraded to the COBRA in just a matter of hours!

Cantrell Machine Co., Inc.

P O Box 757
1400 S. Bradford Street
Gainesville, Ga. 30503

Phone: 770-536-3611
Fax: 770-531-0832
www.cantrell.com



COBRA Viscera Harvester

Model No. CVH-14C

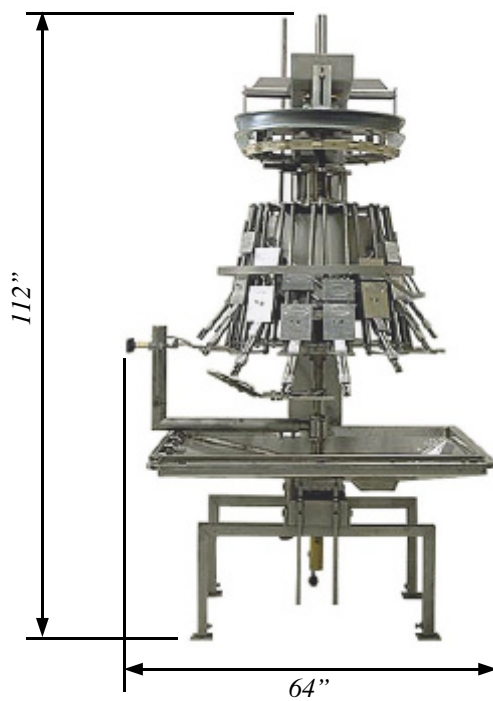

Cobra—14 Unit

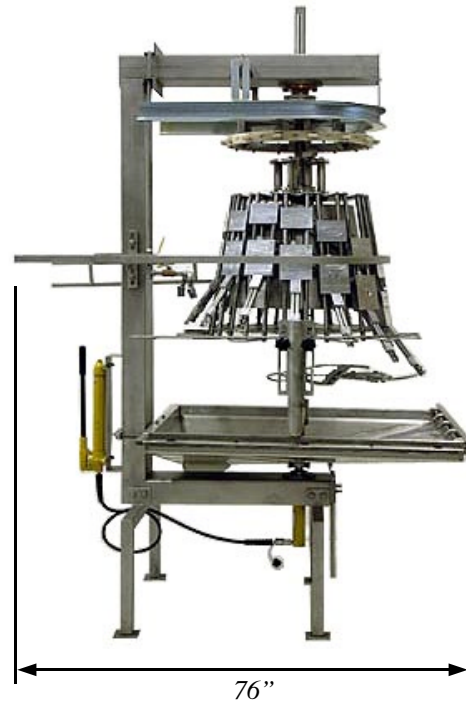

Cobra—20 Unit

TECHNICAL SPECIFICATIONS

	14 Unit	20 Unit
Power:	Overhead driven	Same
Height:	112"	120"
Width:	64"	65 1/2"
Depth:	76"	76"
Water Connection:	3/4"	3/4"
Capacity:	100 bpm	140+ bpm
Position in line:	After Heart & Liver Harvester	Same

The specifications as stated herein are the most current at the time of publication. However, consistent with our standard of continual product improvement, we reserve the right to change the design without notice or obligation to modify any equipment previously sold or delivered.

Cantrell Machine Co., Inc.

P O Box 757 1400 S. Bradford Street

Gainesville, Ga. 30503

770-536-3611

770-531-0832