

# VISCERA HARVESTER

Model No. EH-20

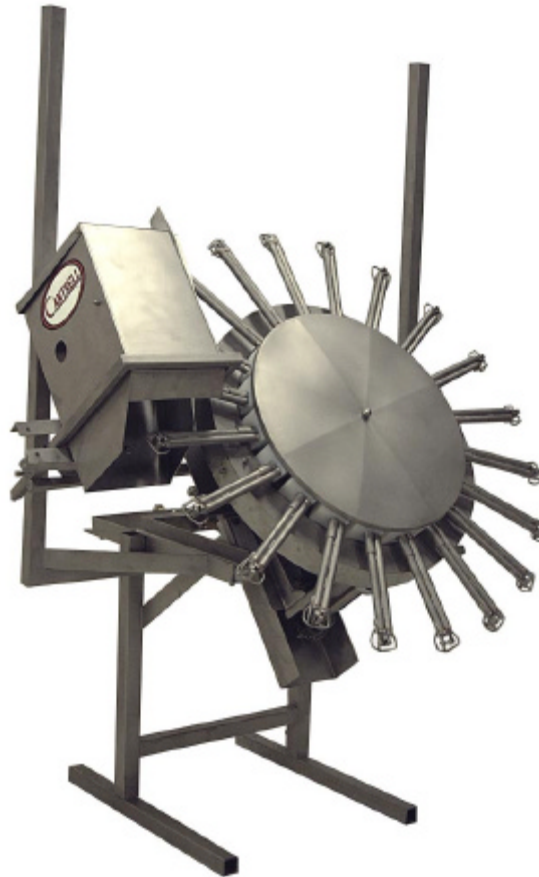

The Cantrell Model EH-20 Viscera Harvester efficiently removes the viscera package and delivers it to the Gizzard Harvester. Installed after the Heart & Liver Harvester, the EH-20 removes the viscera package (including the crop) by clamping onto the proventriculus then pulling the package from the bird. The remaining entrails are released from the clamping device and dropped into the Gizzard Harvester. The unique clamping device provides consistent removal with the package positioned on back of the bird on either the right or left side. The EH-20 is driven by the overhead conveyor, therefore eliminating the need for electricity or air and assuring complete synchronization with the processing line. Constructed of stainless steel and UHMW Polymer, the unit provides easy sanitation with minimal operational adjustments.

Cantrell Machine Co., Inc.

P O Box 757  
1400 S. Bradford Street  
Gainesville, Ga. 30503

Phone: 770-536-3611  
Fax: 770-531-0832  
[www.cantrell.com](http://www.cantrell.com)



# VISCERA HARVESTER

Model No. EH-20

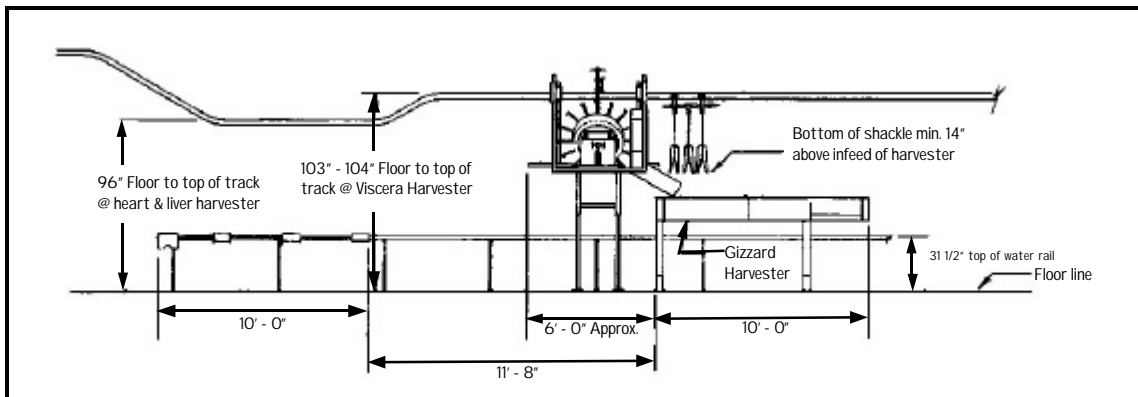
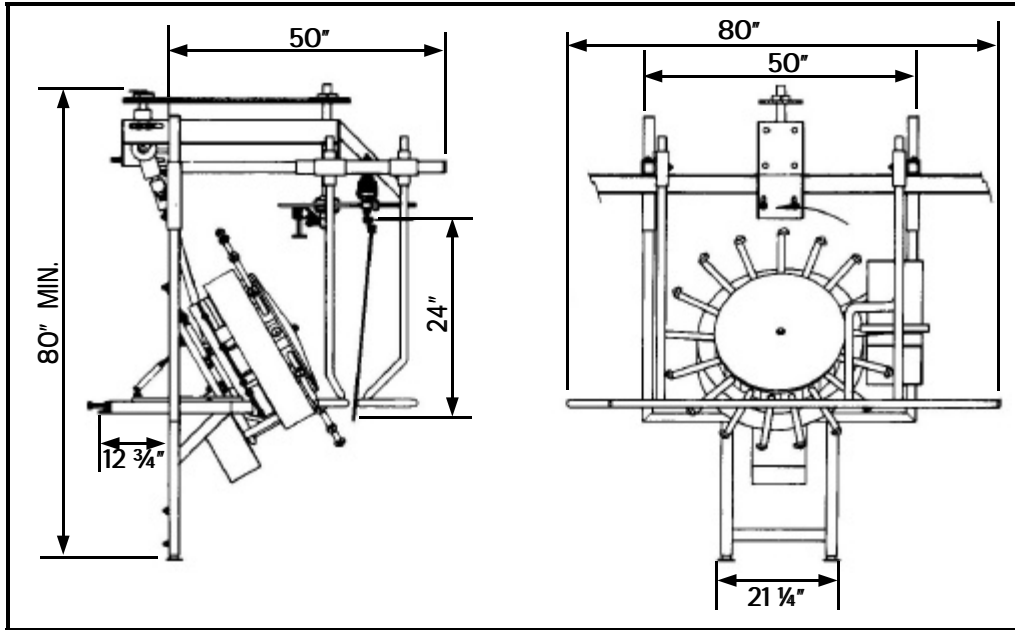

## TECHNICAL SPECIFICATIONS

Position In Line:	After Heart & Liver Harvesting
Capacity:	6000 BPH
Water:	1/2" connection
Installed Power:	1/3 HP Brush Motor
Height:	80"
Width:	50"
Length:	80"
Counter Clockwise Rotation of Machine	Left Hand Machine / RH Viscera Presentation Left Hand Machine / LH Viscera Presentation
Clockwise Rotation of Machine:	Right Hand Machine / RH Viscera Presentation Right Hand Machine / LH Viscera Presentation

The specifications as stated herein are the most current at the time of publication. However, consistent with our standard of continual product improvement, we reserve the right to change the design without notice or obligation to modify any equipment previously sold or delivered.

Cantrell Machine Co., Inc.

P O Box 757 1400 S. Bradford Street Gainesville, Ga. 30503 770-536-3611 (Fax) 770-531-0832