

WHOLE LEG DEBONING LINE

Model No. HBC-110P

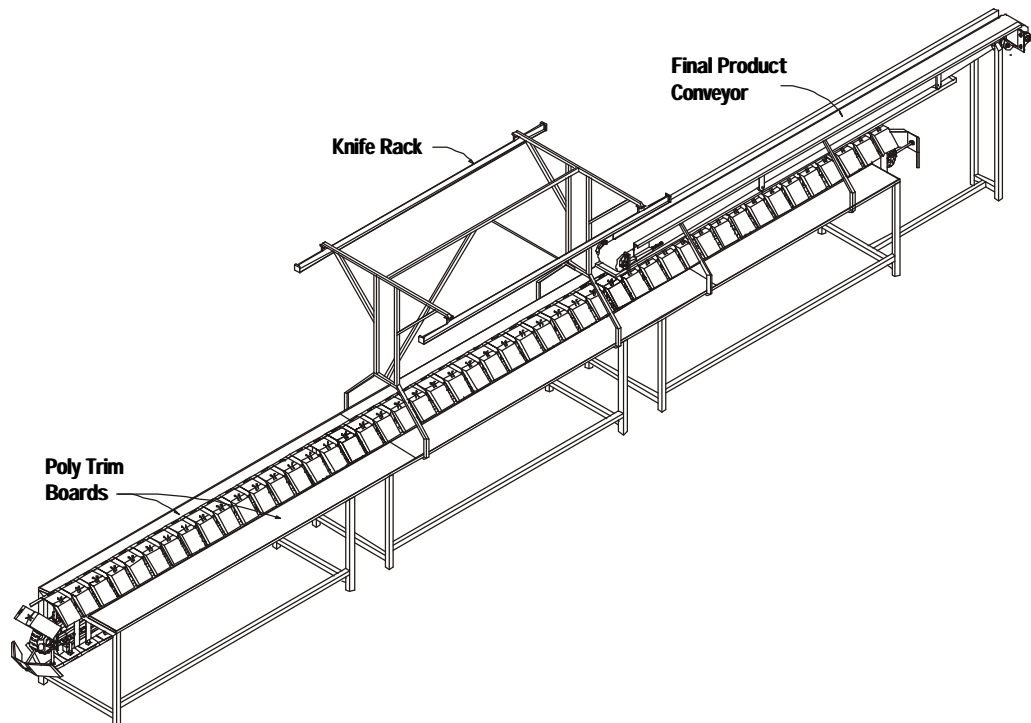

The Cantrell Whole Leg Deboning Line is the most economical dark meat deboning system available today. This system maximizes product output while providing an ergonomically sound working area for personnel. The line is designed to run at a capacity of 30-35 legs per minute on each side with staffing of 8 people per side. Constructed of the highest grade stainless steel, this deboning system can be custom designed to meet individual customer specifications.

Cantrell Machine Co., Inc.

P O Box 757
1400 S. Bradford Street
Gainesville, Ga. 30503

Phone: 770-536-3611
Fax: 770-531-0832
www.cantrell.com



WHOLE LEG DEBONING LINE

Model No. HBC-110P

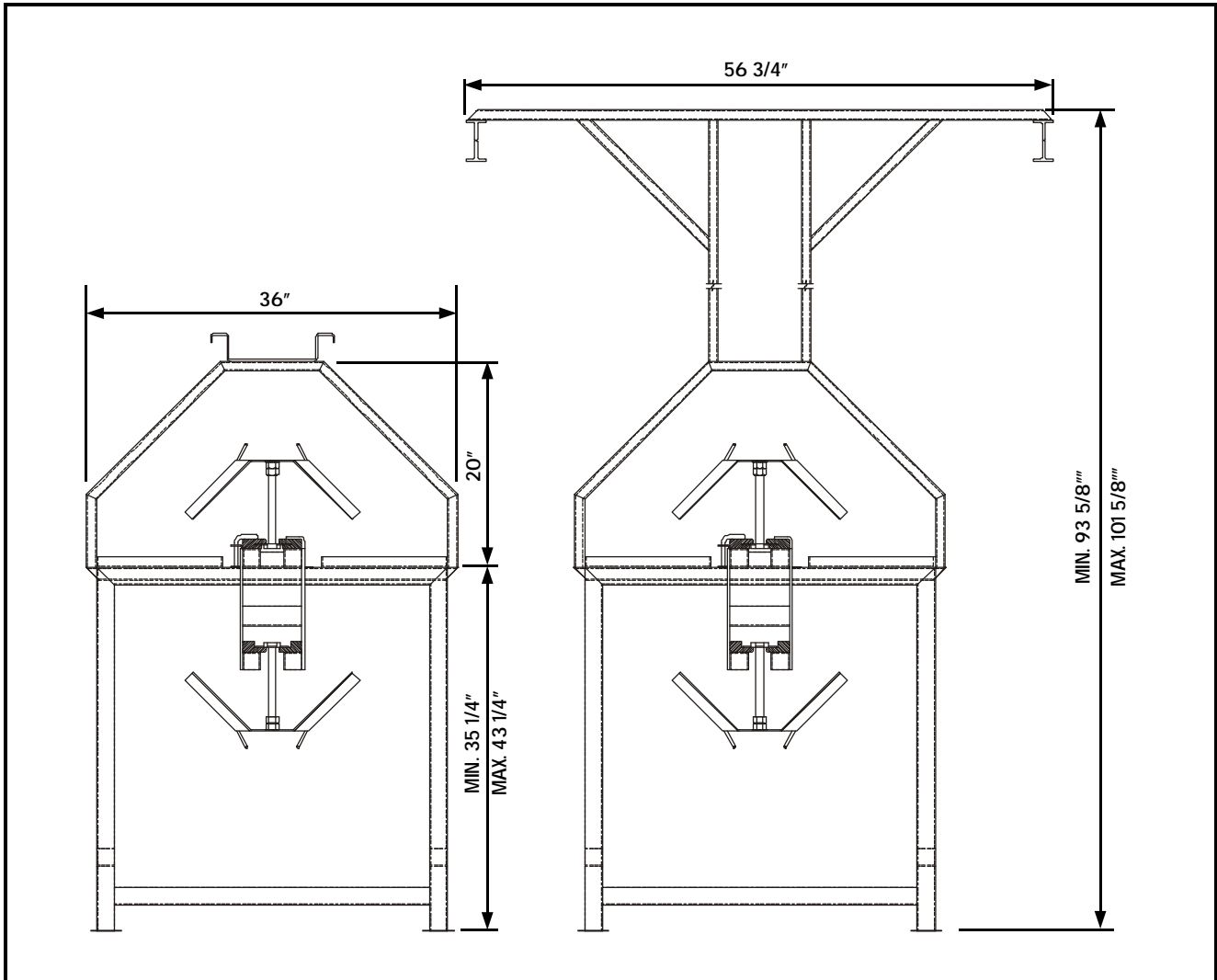

System shown above is not limited to one setup. Length and direction of final product can be customized to meet your specific need. **Note: Product capacity and staffing are subject to change with varying lengths and configurations.*

Cantrell Machine Co., Inc.

P O Box 757 1400 S. Bradford Street

Gainesville, Ga. 30503

770-536-3611

(Fax) 770-531-0832