

▶ Foot Picker / Scalders Model No. CSP-145

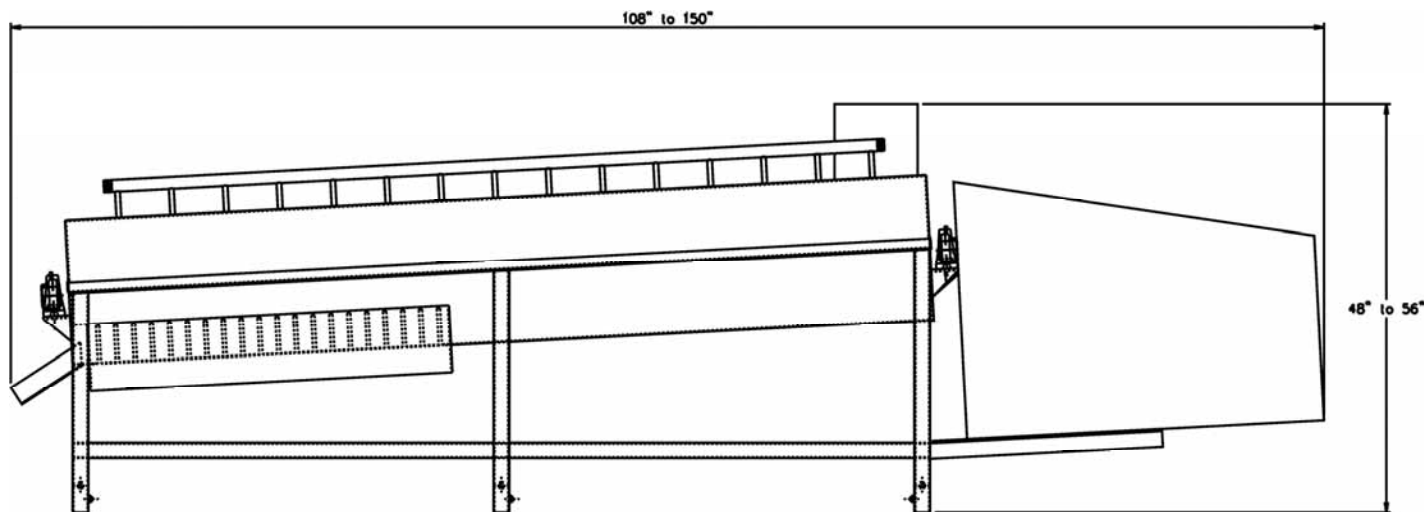

▶ Complete your foot harvesting operation with the CSP-145 Foot Picker / Scalders. The CSP-145 comes in 2 different sizes, a 6 foot barrel and an 8 foot barrel, with a capacity of 364 feet per minute. Power requirements for the 6 foot are one 10hp motor and for the 8 foot one 15hp motor. The 6 foot and 8 foot model shown comes with an air operated top for easy opening.

Foot Picker / Scalders Model No. CSP-145



The specifications as stated herein are the most current at the time of publication. However, consistent with our standard of continual product improvement, we reserve the right to change the design without notice or obligation to modify any equipment previously sold or delivered.