

# CANTRELL

Parts | Equipment | Systems | Solutions

## ▶ Wing Portioner Model No. 6000-DD



▶ The Cantrell direct-drive Wing Portioner cuts wings into two or three parts (drums, flats, tips) and handles both broilers and roasters. This portioner will process left, right and inter-mixed wings. It operates efficiently at 50-60 wings per minute due to the unique design of the wheel and cutting blades. Manufactured of stainless steel and nylon, these compact machines may be installed in a multiple unit system. An optional 3-chute slide accommodates the parts into a divided conveyor.

# CANTRELL

Parts | Equipment | Systems | Solutions

## ▶ Wing Portioner Model No. 6000-DD

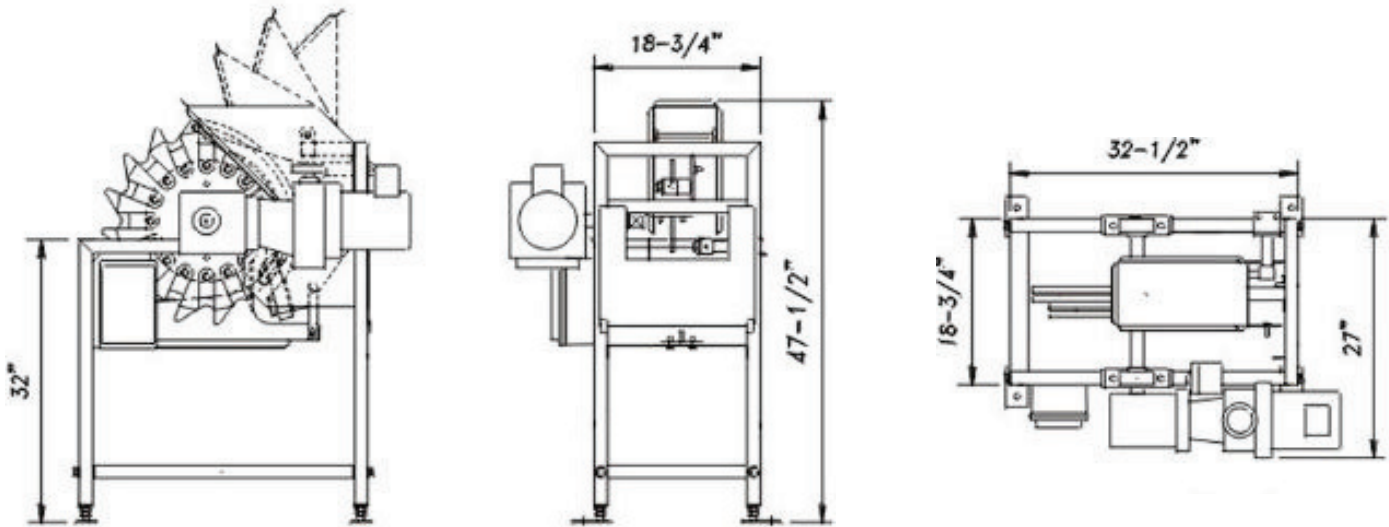

### TECHNICAL SPECIFICATIONS

Capacity:	50 to 60 Wings Per Minute
Power:	1/2 HP Variable Speed / .37 kw
Water Consumption:	1 Gal. Per Minute Max / 3.785 Liter Per Minute
Water Connection:	1/2 NPT
Dimensions:	Shown
Levelers/Adjustment:	+ 3 in. / + 76 mm
Net Weight:	330 lbs. Approx. / 150 kg Approx.
Gross Weight:	400 lbs. Approx. / 181 kg Approx.

The specifications as stated herein are the most current at the time of publication. However, consistent with our standard of continual product improvement, we reserve the right to change the design without notice or obligation to modify any equipment previously sold or delivered.